

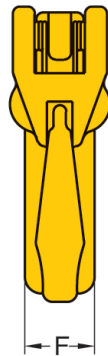

# Grade 80 Excavator Weld-On Hook

## Product Specification Sheet

Manufactured to BS EN 1677-1+2

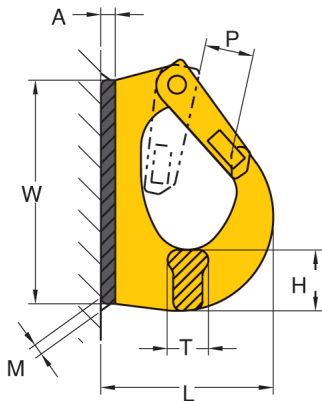

Deutsch BG-Prufzert Type  
Approval for Grade 80 Lifting Chain  
Components with H91 Certified



### DIMENSIONAL SPECIFICATIONS

Part Code	W.L.L. tonnes	Dimensions mm							
		P	L	T	H	F	W	A	M
8-081-01	1.0	18	70	18	27	25	95	7	4
8-081-02	2.0	25	85	20	30	30	115	8	5
8-081-03	3.0	28	107	23	30	35	133	9	6
8-081-04	4.0	28	114	30	38	42	142	10	7
8-081-05	5.0	30	135	31	47	44	167	12	7
8-081-08	8.0	32	137	39	52	50	176	12	8
8-081-10	10.0	44	170	42	56	56	222	13	8

Customers purchasing GRADE 80 EXCAVATOR WELD-ON HOOK may also require:

### LATCH KITS FOR EXCAVATOR WELD ON HOOK



Part Code	Size (tonnes)
8-P081-01	1.0
8-P081-02	2.0
8-P081-03	3.0
8-P081-04	4.0
8-P081-05	5.0
8-P081-08	8.0
8-P081-10	10.0

Ivy Farm Workshops • High Street • Coddendam • Ipswich • Suffolk IP6 9QX

Tel: 01449 761705

Email: [lifting@bickerslifting.co.uk](mailto:lifting@bickerslifting.co.uk) • Web: [www.bickerslifting.co.uk](http://www.bickerslifting.co.uk)